

- > Port size: G1/2 ... 1
- > High flow rate
- > Variable valve solenoid combination
- > Standard manual override with normally closed valves



Technical features

Medium:
Compressed air, filtered, lubricated or non-lubricated

Operation:
Indirect solenoid operated poppet valve (versions with external pilot port available)

Operating pressure:
See table below

Orifice:
12 ... 25 mm

Port size:
G1/2, G3/4 or G1

Flow direction:
Fixed

Mounting position:
Any, but preferably with solenoid vertical

Ambient/Media temperature:
-10 ... +60°C (-13 ... +176°F)
Depending on solenoid system.
Air supply must be dry enough to avoid ice formation at temperatures below +2°C (+35°F).

Material:
Body: Aluminium
Inner parts: POM
Seals: PUR

Further versions
With manual override
Others on request

Flow conversion:
Cv US Gallon/min (water) =
l/min (air) x 0,001
Kv m³/h (water) =
l/min (air) x 0,000906

Technical data - Standard version

Symbol	Port size	Orifice (mm)	Actuation/return	Pilot supply	Flow (l/min)	Operating pressure (bar)	Pilot pressure (bar)	Switching time (ms)	Weight (kg)	Dimension No.	Model *1)
	G1/2	12	Solenoid/spring	Internal	3000	1 ... 16	-	20	0,2	1	7030117
	G3/4	20	Solenoid/spring	Internal	8500	1 ... 16	-	25	1,2	3	7032130
	G1	25	Solenoid/spring	Internal	8500	1 ... 16	-	25	1,2	3	7032230
	G3/4	20	Solenoid/spring	Internal	8500	1 ... 15	-	25	1,2	3	7032630
	G1	25	Solenoid/spring	Internal	8500	1 ... 15	-	25	1,2	3	7032730
	G3/4	20	Solenoid/spring	External	8500	0 ... 15	1 ... 16	25	1,2	3	7032131
	G1	25	Solenoid/spring	External	8500	0 ... 15	1 ... 16	25	1,2	3	7032231
	G3/4	20	Solenoid/spring	External	8500	0 ... 14	1 ... 15	25	1,2	3	7032631
	G1	25	Solenoid/spring	External	8500	0 ... 14	1 ... 15	25	1,2	3	7032731





*1) When ordering please indicate solenoid, voltage and current type (frequency).

Vacuum version

Symbol	Port size	Orifice (mm)	Actuation/return	Pilot supply	Flow (l/min)	Operating pressure (bar)	Pilot pressure (bar)	Switching time (ms)	Weight (kg)	Dimension No.	Model *1)
	G1/2	12	Solenoid/spring	External	3000	-1 ... +6	4 ... 10	20	0,55	2	7030118
	G3/4	20	Solenoid/spring	External	8500	-1 ... +6	4 ... 10	25	1,2	3	7032132
	G1	25	Solenoid/spring	External	8500	-1 ... +6	4 ... 10	25	1,2	3	7032232
	G1/2	12	Solenoid/spring	External	3000	-1 ... +6	4 ... 10	20	0,55	2	7030709
	G3/4	20	Solenoid/spring	External	8500	-1 ... +6	4 ... 10	25	1,2	3	7032632
	G1	25	Solenoid/spring	External	8500	-1 ... +6	4 ... 10	25	1,2	3	7032732

*1) When ordering please indicate solenoid, voltage and current type (frequency).

Solenoids group, standard voltages

	Power consumption		Rated current		Protection class IP/NEMA	Ex-Protection (ATEX-Category)	Temperature Ambient/ Media (°C)	Electrical connection	Weight (kg)	Drawing No.	Circuit diagram No.	Model
	24 V d.c. (W)	230 V a.c. (VA)	24 V d.c. (mA)	230 V a.c. (mA)								
	12,1	15	504	63	IP65 (with connector)	—	-25 ... +60 Media: +80 max	Connector DIN EN 175301-803, form A *2)	0,117	1	1	0200
	10,7	—	446	—	IP66	II 2 G Ex mb IIC T4 Gb II 2 D Ex mb IIC T110°C Db	-20 ... +40	Cable length 3 m	0,4	5	4	0290
	—	12,4	—	54	IP66	II 2 G Ex mb IIC T4 Gb II 2 D Ex mb IIC T110°C Db	-20 ... +40	Cable length 3 m	0,4	5	7	0291
	11,4	—	475	—	IP66 (with cable gland)	II 2 G Ex e mb IIC T4/ T5 Gb II 2 D Ex tb IIC T130°C Db IP66	T4: -40 ... +50 T5: -40 ... +40 -40 ... +50	M20 x 1,5 *2)	0,5	6	4	4230
	—	15,2	—	66	IP66 (with cable gland)	II 2 G Ex e mb IIC T4/ T5 Gb II 2 D Ex tb IIC T130°C Db IP66	T4: -40 ... +50 T5: -40 ... +40 -40 ... +50	M20 x 1,5 *2)	0,5	6	7	4231
	13,6	—	567	—	4x	Cl. I, Div. 1, Gr. A - D Cl. II/III, Div. 1, Gr. E - G T3C (160°C)	-20 ... +60	Flying leads length 460 mm	0,5	8	1	3726
	—	15,7	—	68	4x	Cl. I, Div. 1, Gr. A - D Cl. II/III, Div. 1, Gr. E - G T3C (160°C)	-20 ... +60	Flying leads length 460 mm	0,5	8	5	3727

Standard voltages (±10%) 24 V d.c., 230 V a.c., other voltages on request. Design according to VDE 0580, EN 50014/50028. 100% duty cycle.
*2) Connector/cable gland is not scope of delivery, see table »Accessories«.

Approvals

Model	Approvals ATEX	IECEX	FM
029x	KEMA 02 ATEX 1347 X	IECEX DEK 13.0014X	—
372x	—	—	CSA-LR 57643-6

Model	Approvals ATEX	IECEX
42xx	KEMA 98 ATEX 4452 X	IECEX KEM 09.0068X

Accessories

Electrical connection

Cable gland
Protection class
Ex e, Ex d



Page 9

Thread	Cable Ø (mm)	Materials	Protection class (ATEX)	Model
M20 x 1,5	5 ... 8	Nickel plated brass	II 2 GD Ex e	0588819
M20 x 1,5	9 ... 13	Stainless steel 1.4571 (316 Ti)	II 2 GD Ex e	0589385

Connector
DIN EN 175301-803



0570275 (form A)

Item numbers for international approvals

Country/Approvals	Solenoid series/Code 42xx
China/NEPSI	-01
Brasil/INMETRO	-02
Korea/KOSHA	-03
Russia, Kazakhstan & Belarus/TR-CU 012	-04
India/CCOE	Standard number
Taiwan/ITRI	Standard number

Example: 0000000423002400-03
(Solenoid: 4230; Power consumption: 24 V d.c.; Approval: KOSHA)

Drawings - Valve

 Dimensions in mm
 Projection/First angle

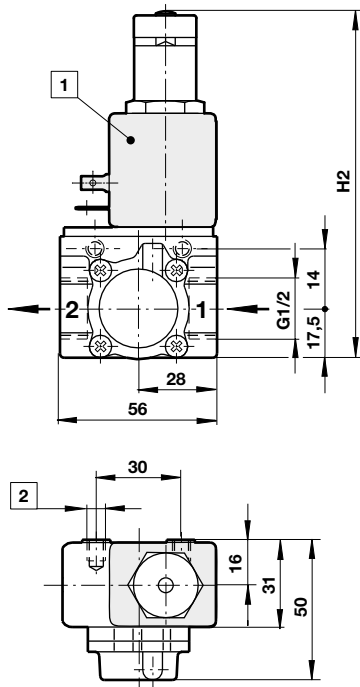
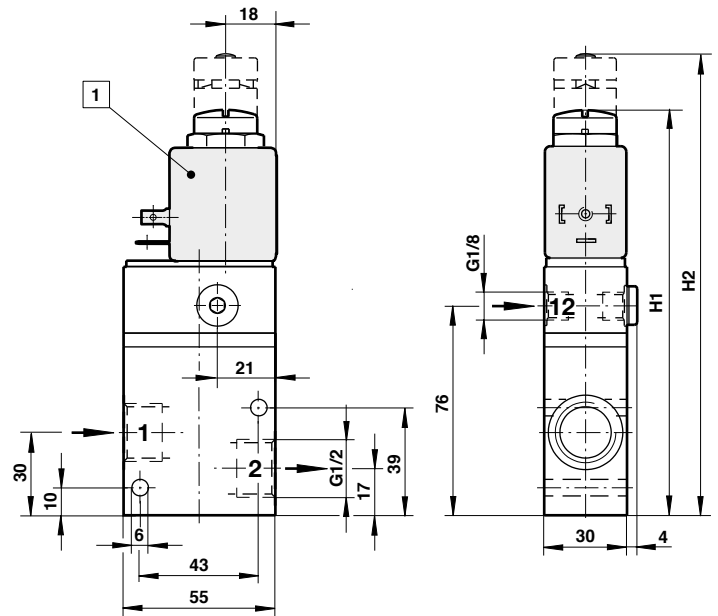
1

2

- 1 Solenoid rotate 4 x 90°
2 M6 x 7,5 deep

H2 *3)	Model
121	7030117

*3) With manual override

H1 *4)	H2 *5)	Model
-	167	7030118
147	-	7030709

- *4) Without manual override
 *5) With manual override

3

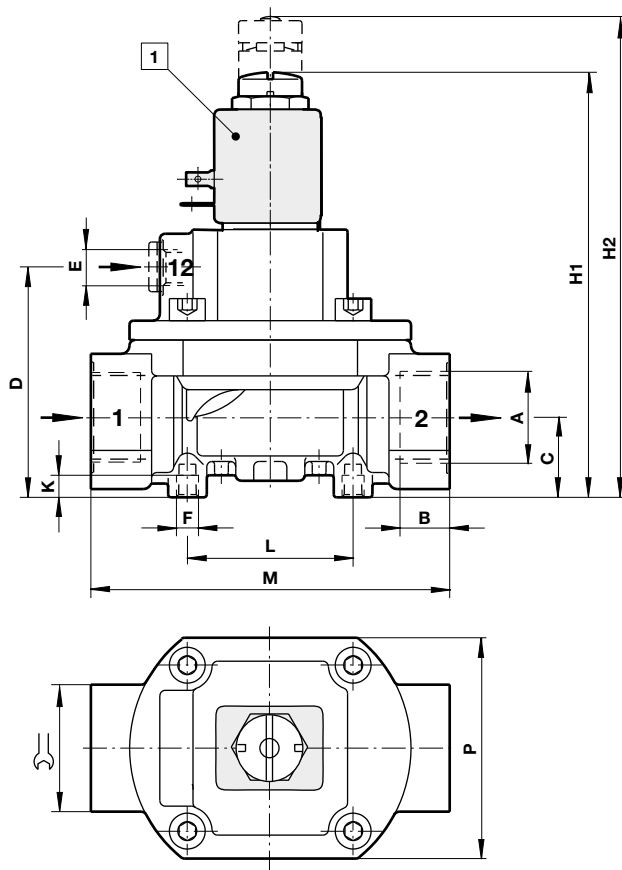

1 Solenoid rotate 4 x 90°

A	B	C	D	E	H1 *6)	H2 *7)	F	K	L	M	P		Model
G3/4	20	29	83,5	G1/4	-	174	M8	8	60	130	80	46	703213
G3/4	20	29	83,5	G1/4	154	-	M8	8	60	130	80	46	703263
G1	18	29	83,5	G1/4	-	174	M8	8	60	130	80	46	703223
G1	18	29	83,5	G1/4	154	-	M8	8	60	130	80	46	703273

*6) Without manual override

*7) With manual override

Drawings - Solenoid

Dimensions in mm
Projection/First angle

1

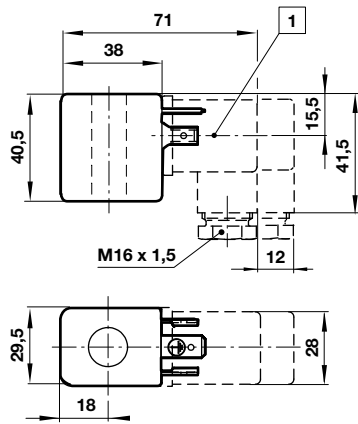

5

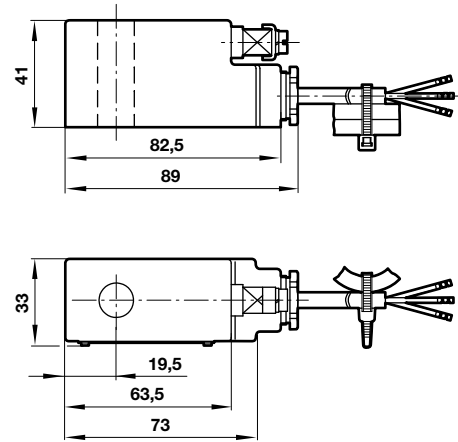

6

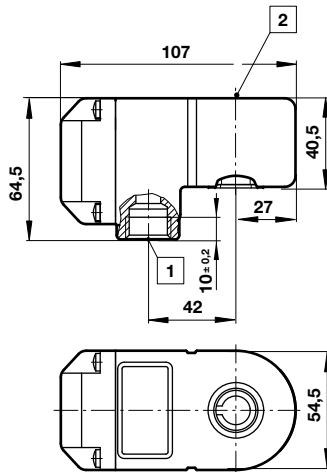

8

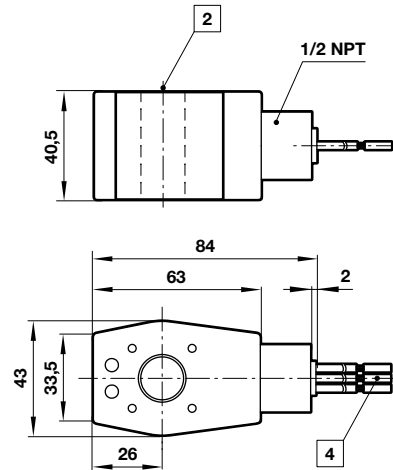

- 1 Connector can be indexed by 4x90°
- 2 Ø 13
- 3 M20 x 1,5
- 4 Flying leads AWG 18 (460 mm long)

Circuit diagrams

1

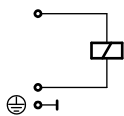

4

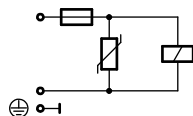

5

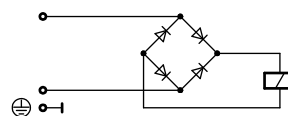

7

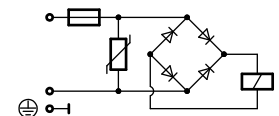

Cable gland

Dimensions in mm
Projection/First angle

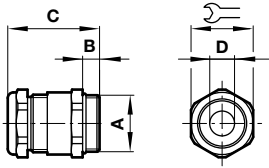

A	B	C	ø D		Model
M20 x 1,5	9	36	5 ... 8	22	0588819
M20 x 1,5	6,5	27,5	9 ... 13	22	0589385

Warning

These products are intended for use in industrial compressed air systems only. Do not use these products where pressures and temperatures can exceed those listed under »**Technical features/data**«.

Before using these products with fluids other than those specified, for non-industrial applications, life-support systems or other applications not within published specifications, consult IMI Precision Engineering, Norgren GmbH.

Through misuse, age, or malfunction, components used in fluid power systems can fail in various modes. The system designer is warned to consider the failure modes of all component parts used in fluid power systems and to provide adequate safeguards to prevent personal injury or damage to equipment in the event of such failure.

System designers must provide a warning to end users in the system instructional manual if protection against a failure mode cannot be adequately provided.

System designers and end users are cautioned to review specific warnings found in instruction sheets packed and shipped with these products.